

**MODEL: M3000 robust d.c.**

Robust panel mounted d.c. motor with conventional 2-roller rotor design, simple easy to use tube loading system with quick release front cover. Flow rates of up to 3408ml/min.



Pump head: Aluminium alloy. Polyester coated for chemical resistance

Motor: Permanent magnet motor with worm drive gearbox

Rotor: Anodised aluminium alloy with Nylatron rollers as standard

Power Supply: 12/24v d.c.

Tube: Silicone, Autoprene, Tygon, Viton, Prothane 6.3mm, 8.0mm & 9.5mm

Weight: 2 kgs

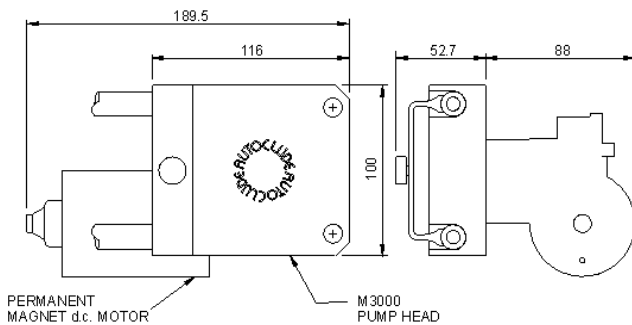

FLOW RATES ml/min			
TUBE	55 RPM	125 RPM	240 RPM
6.0mm	407.0 ml/min	925.0 ml/min	1776.0 ml/min
8.0 mm	643.5 ml/min	1462.5 ml/min	2808.0 ml/min
9.5 mm	781.0 ml/min	1775.0 ml/min	3408.0 ml/min